



**IN-TANK TECHNOLOGY**



PLEASE NOTE OUR NEW STREET ADDRESS  
Custom Masters/Flo King Filter Systems  
401 Lake Bennett Ct.  
Longwood, FL 32750-6341 USA

# FLO KING LAB SERIES OPERATIONS MANUAL

[www.floking.com](http://www.floking.com)

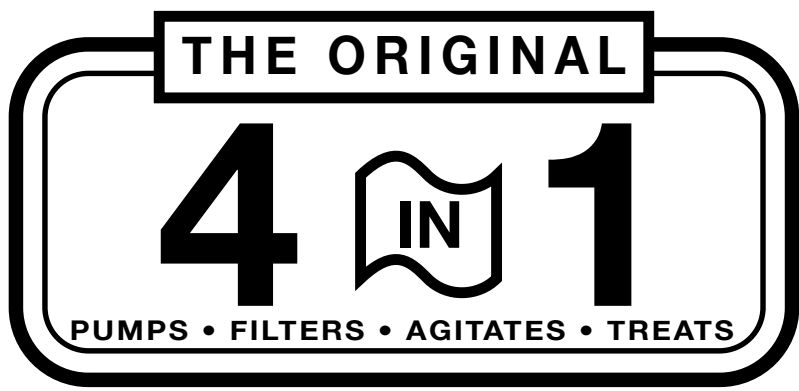

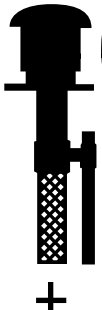

# LAB SERIES OPERATIONS MANUAL

## WELCOME TO THE FLO KING EXPERIENCE!

Congratulations on your purchase of the Flo King Lab Series in-tank, sealless, centrifugal pump. This 4-in-1 unit can be used to pump, filter, agitate, and treat a wide variety of chemical- and metal-containing solutions. The Lab Series has a maximum flow rate of 400 gallons per hour (1500 liters/hour).

Because of the unique design of the Lab Series and our selection of high-quality reusable and disposable filter media, the life of process baths and associated pre- and post-treatment formulations can be extended while using fewer cartridges.

The excellent agitation and counterflow action produced by the Lab Series also result in uniform solution temperature and chemical consistency, as well as continual recirculation to carry surface particulates down to the filter media for efficient removal.

The Lab Series also eliminates leaks and spills that can present environmental and safety problems.

Flo King pumps and filter systems are built to last. To maximize the performance and life of your Flo King system, it is important that you read and understand the instructions in this manual.

## BEFORE UNPACKING YOUR UNIT

Follow these instructions before unpacking your Flo King system:

- 1.** Inspect contents before removing pump from shipping container to make certain that no damage has occurred during shipment.
- 2.** Before removing pump from shipping container, plug pump cord into properly grounded ac outlet of the correct voltage for the unit you have ordered, and run pump to make sure damage has not occurred during shipping.
- 3.** If unit seems to be damaged, notify carrier (UPS, etc.) at once, then notify CUSTOM MASTERS INC., manufacturer of the Flo King system, at 407-331-4634 (FAX 407-331-0575) for further instructions.



## LIMITED ONE-YEAR AND 90-DAY GUARANTEE

The Flo King Motor is guaranteed for 90 days against defects in material and workmanship.

All other Flo King filter system components are guaranteed for one year from date of purchase against defects in material and workmanship.

This guarantee does not cover damage caused by misuse or negligence. If the Flo King filter system fails to operate during the guarantee periods, notify CUSTOM MASTERS for repair or replacement without charge at the manufacturer's option. If unit must be replaced, the transportation costs for returning the defective pump are the responsibility of the consumer.

Dismantling the Motor from the pump in any way may void this guarantee.

## SAFETY PRECAUTIONS

All safety-related procedures must be followed to prevent injury or damage to personnel, the workplace, and the environment. These include the following:

1. Make sure only trained and qualified personnel install, use, and maintain Flo King equipment. Handling of any equipment by unauthorized personnel can be dangerous.
2. Always wear proper protective gear such as gloves, aprons, and goggles.
3. To avoid electrical shock, never handle this equipment when wet or standing in water.

When handling equipment for any reason, make sure power supply is disconnected.

4. Do not lift or suspend Motor by power supply cord.
5. Use only the power supply cord furnished with the Lab Series. Do not alter the factory-furnished power supply cord. Plug the cord into a properly grounded outlet of the correct voltage for the unit you have ordered. Do not use an extension cord!
6. Keep power supply cord out of contact with hot, sharp, highly corrosive and other potentially damaging objects and solutions.

## ELECTRICAL & ANTI-FIRE WARNINGS

1. Use only the power supply cord furnished with the Lab Series.
2. Do not alter the factory-furnished power supply cord.
3. Plug the factory-furnished cord into a properly grounded outlet of the correct voltage for the unit you have ordered.
4. Do not use an extension cord!
5. Keep factory-furnished power supply cord out of contact with hot, sharp, highly corrosive and other potentially damaging objects, materials, and solutions.

Failure to abide by these measures will void the Flo King warranty and relieve Custom Masters from any and all electrical and fire liability claims.



# FLO KING LAB SERIES FILTER SYSTEM

Thumbscrew  
for Universal  
Bracket

Universal  
Bracket

Weep Hole

Impeller Housing

Motor Cover

Pump/Motor Base

Pump Body

Discharge Port

45° Elbow

2" Outlet  
Extension

Filter Screw  
(also called Thumbscrew)

Filter Cartridge

Insert Filter Plug here

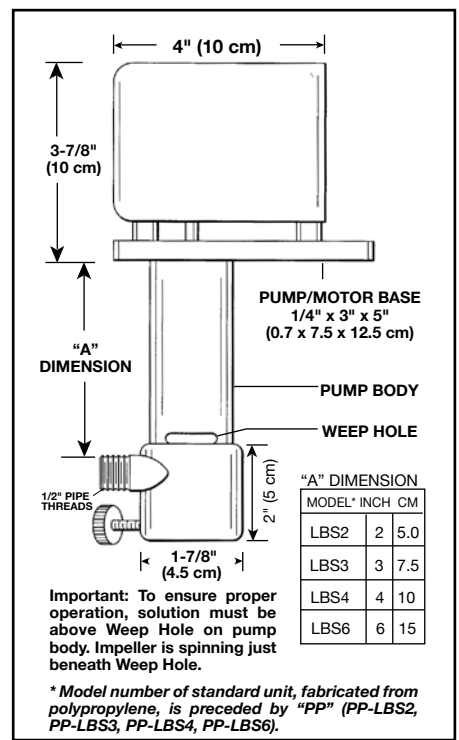



# FLO KING IN-TANK LAB SERIES FILTER SYSTEM

## For tanks as small as a half-gallon and larger!

This is a ready-to-operate filter system complete with all accessories illustrated. It is powered by a super-quiet, ball-bearing, continuous-duty motor.

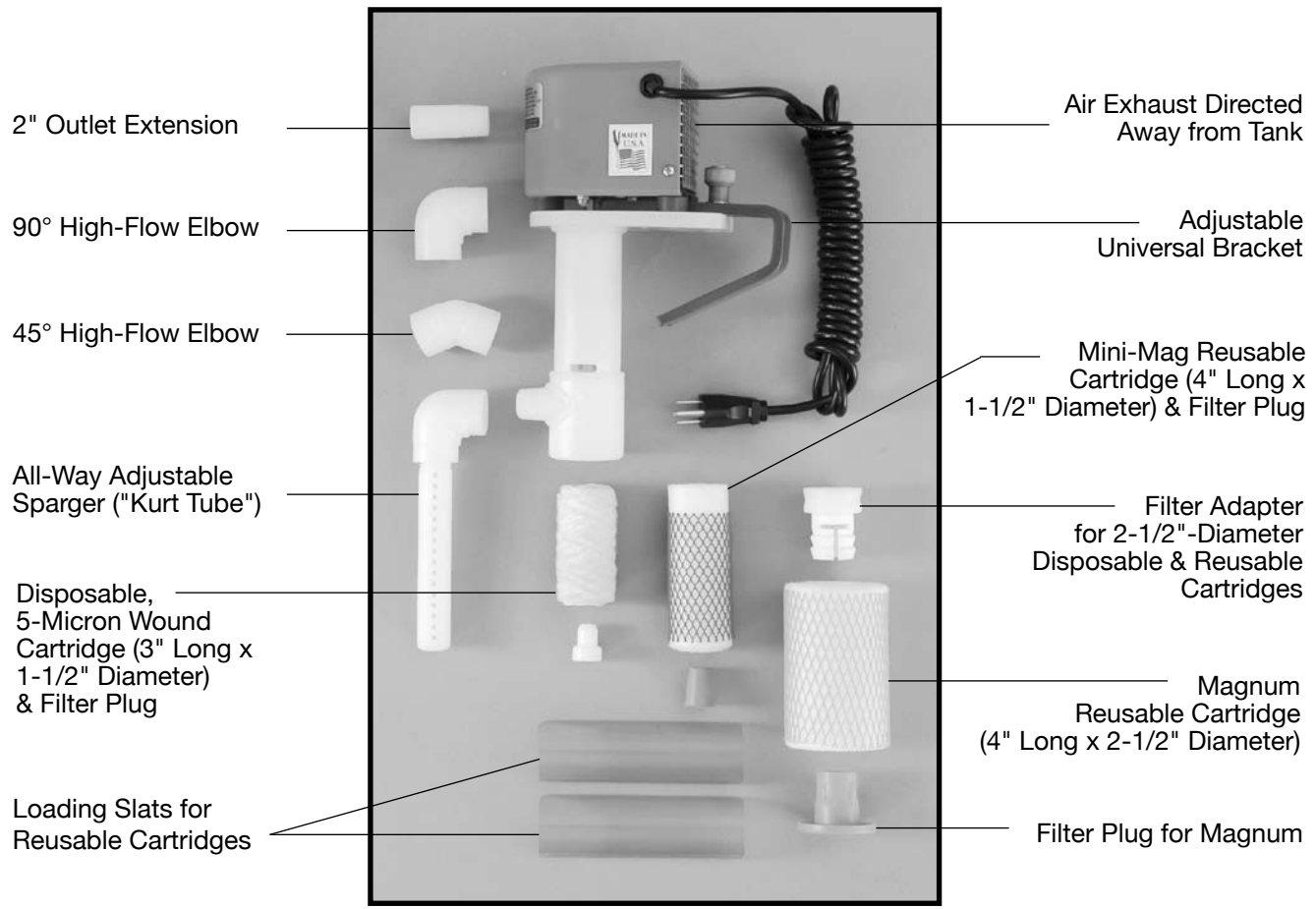

### FLO KING LAB SERIES SPECIFICATIONS

**PUMP:** Standard unit is made of polypropylene with Teflon-covered 303 stainless-steel shaft. Pump also available on special-order basis in PVDF (Kynar), stainless steel, and CPVC. Titanium shaft also available (call for pricing).

**FLOW RATE:** Up to 400 gallons per hour (1500 liters per hour) at 60 Hz, depending on type of filter cartridge and attachments used. A flow-rate reduction of 18%(±3%) is typical when operated at 50 Hz.

**MOTOR:** 1/70th horsepower (11 watt), single phase, thermally protected. When ordering, specify one of the following motors:

- 115 volts, 50/60Hz, 2600/3000 RPM, 0.96 A
- 230 volts, 50/60Hz, 2600/3000 RPM, 0.48 A



## LAB SERIES INSTALLATION

The Flo King Lab Series filter system is preassembled and ready to operate after removal from the box. Referring to Pages 3 and 4 for parts identification, just follow these instructions:

1. Insert preferred filter cartridge into Impeller Housing and tighten Filter Screw (thumb-screw) to hold in place. The 1-1/2"-diameter **Poly-Wrap Disposable Filter Cartridge** and 1-1/2"-diameter **Mini Mag Reusable Filter** fit directly into Impeller Housing. To use larger, 2-1/2"-diameter **Magnum Reusable Filter** (or other 2-1/2"-diameter filter not included with Lab Series Filter System), first insert Filter Adapter into Impeller Housing.

CAUTION: Do not over- or under-tighten Filter Screw. Just tighten snug enough to hold filter in place.

For information on filter selection, please refer to Page 8, "Flo King LAB SERIES FILTER CARTRIDGES."

2. Insert appropriate Filter Plug into hole at bottom of filter cartridge.

3. Screw appropriate attachment (45° Elbow, Kurt Tube or 90° Elbow) onto Discharge Port. The 45° Elbow provides the most vigorous agitation and highest flow rate. The Kurt Tube (Adjustable Dispersion Tube) provides gentler, uniform agitation. The 90° Elbow is generally recommended for narrow, deep tanks.

4. Screw 2-inch Outlet Extension onto 45° or 90° Elbow if elbow has been selected as preferred attachment for Discharge Port. The Outlet Extension streamlines flow from Discharge Port, creating a smooth, highly directable source of solution circulation. (Note: Outlet Extension is not used with Kurt Tube.)

5. Turn selected attachment on Discharge Port as necessary to achieve desired *counter-flow agitation pattern* in tank. Each attachment can be turned 360°. Generally, it is desirable to mount Lab Series pump in corner of tank and adjust selected attachment as follows:

- 45° Elbow with Outlet Extension: Slant Elbow/Extension at a slight angle (about 5°) downward toward tank wall rather than toward center of tank.

- Kurt Tube: Position vertically or horizontally as dictated by tank and parts configurations.

- 90° Elbow with Outlet Extension: Suggested for narrow, deep tanks. Aim Elbow/Extension straight down and slightly toward tank wall.

Counterflow agitation is important to continually skim solution surface and keep particles in suspension so they can be captured quickly by filter media and not settle on tank bottom. This is achieved as natural byproduct of filtration with Flo King system as filtered solution is expelled through Discharge Port and appropriate attachment.

6. Loosen Filter Screw on Universal Bracket to release sliding mechanism. Place pump in accessible area of tank (preferably in corner) to accommodate filter changes and maintenance. Then slide Universal Bracket against tank lip and tighten thumbscrew to secure pump to tank.

**WARNING:** The Lab Series Motor is open-faced (not totally enclosed) and therefore is not recommended for use in unventilated areas or uncovered tanks containing hot, highly corrosive, fuming solutions.

7. Check to make sure that "Weep Hole" on pump Body immediately above Discharge Port is submerged at least 1 inch (25 mm) beneath solution. This will ensure that the Impeller is spinning in solution. The Impeller must be submerged for pump to function properly, to ensure self-priming operation, and to prevent aeration and/or foaming of solution.

8. Plug electrical cord into properly grounded ac outlet of the correct voltage for the unit you have ordered. (Do not use an extension cord!) The pump will begin operating as soon as it is plugged in.

9. If necessary, readjust attachment on Discharge Port to modify agitation pattern in tank.



## REMOVING LAB SERIES FROM TANK AND CHANGING FILTER CARTRIDGES

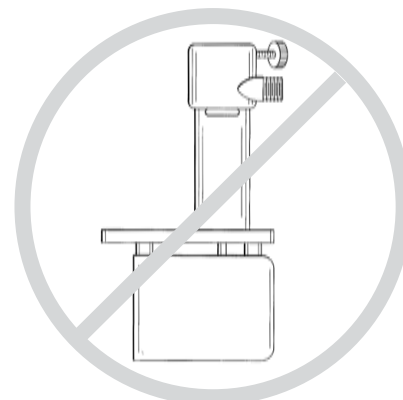

Refer to Safety Precautions on Page 2.  
Solution Safety Procedures Must Be Followed  
To Prevent Injury or Damage to Personnel and Environment.

### **Warning! Do Not Turn Flo King System Upside Down!**

Do not turn Flo King system upside down when changing filter cartridges or any other time it has been exposed to corrosive solution! When pump is turned upside down, solution can drain onto Motor area and be drawn into Motor by vacuum when Motor cools after power is turned off. Also, if laying pump on side to change filters, make sure solution does not drain onto Motor.

There are two ways to remove your Flo King from the tank. Here is the first procedure:

1. Unplug cord.
2. Grasp Motor Cover. (Caution! Cover may be hot—allow to cool and use gloves).
3. Tilt pump back slowly. This will allow Universal Bracket to clear tank lip for removal.
4. Lift pump out of solution. Do so slowly to avoid dislodging sludge, particulates, and other debris captured by and adhering to filter media.
5. When removing pump from tank, it is advisable to set up a bucket or other receptacle near the tank. Let pump and filter cartridge drain into vessel to avoid dripping solution onto floor.
6. Loosen Filter Screw and allow dirty filter cartridge to drop into receptacle.
7. Attach new filter cartridge.

Here is the second, alternate procedure:

1. Unplug cord.
2. Loosen thumbscrew on Universal Bracket.
3. Pull Universal Bracket out (away from tank).
4. Lift pump straight up, out of solution. Do so slowly to avoid dislodging sludge, particulates, and other debris captured by and adhering to filter media.
5. When removing pump from tank, it is advisable to set up a bucket or other receptacle near the tank. Let pump and filter cartridge drain into vessel to avoid dripping solution onto floor.
6. Loosen Filter Screw and allow dirty filter cartridge to drop into receptacle.
7. Attach new filter cartridge.



## LAB SERIES OPERATING INSTRUCTIONS

### Continuous or Periodic Operation

Your Flo King Lab Series system can be used either continuously—24 hours a day—or periodically, as need arises.

### Exposure and Immersion Warnings

The Lab Series filter system is designed for clean laboratory, prototype and small production operations. It is not recommended for use in unventilated areas or uncovered tanks containing hot, highly corrosive, fuming solutions. Use of the Lab Series in these types of hostile environments without proper precautions will void the guarantee.

Do not mount the Flo King pump in front of the ventilation exhaust. This will have the effect of exposing the Motor to a continuous draft of corrosive fumes that will shorten Motor life.

Never immerse the Flo King Motor in any solution. Immersion may cause Motor failure and will void the Flo King guarantee.

## PERIODIC MAINTENANCE PROCEDURE

Refer to Safety Precautions on Page 2.

Solution Safety Procedures Must Be Followed

To Prevent Injury or Damage to Personnel and Environment.

The suggested Motor maintenance procedure is as follows:

1. Disconnect electrical power supply by unplugging Flo King unit.
2. Remove pump from solution.
3. As needed to remove dust or dry dirt buildup on Motor, blow compressed air (not to exceed 30 psi) through Screen at rear of Motor Cover. (NOTE: Compressed air is not recommended if there is a *moist* residue buildup inside Motor Cover.)
4. To remove any *moist* residue buildup inside Motor Cover, allow Motor to cool, then loosen three screws at rear of Motor Cover to remove Screen. Carefully slide Motor Cover forward, being careful not to pinch electrical cord or bend Motor Fan Blades. Clean out residue with cotton swab, brush or other suitable tool.
5. Reassemble unit and resume operation. When reassembling, make sure not to pinch electrical cord or bend Motor Fan Blades. *Motor Fan Blades should never touch Motor or Motor Cover.*

**CAUTION:** Never plug in pump while Motor Cover is removed!

### Exterior of Motor

Unplug unit, then use damp rag to wipe down exterior of Motor Cover as needed to promote general cleanliness and cool, efficient operation.



## FLO KING LAB SERIES FILTER CARTRIDGES

For flexibility, three types of filter cartridges are included with your Lab Series filter system. They are as follows:

**1. Poly-Wrap:** This is a 10-micron, 1-1/2"-diameter (38-mm), 4"-long (102-mm) disposable cartridge that is inserted directly into the Lab Series pump (Filter Adapter not required). It is used in small tanks where there is not enough space for a wider or longer cartridge. *Flo King Reorder #FKLAB10-4.* **Purity Information:** Poly-Wrap may contain a surfactant or mineral oil at less than 1 percent. Immersion in boiling deionized water may be desirable for sensitive applications.

**2. Mini Mag Reusable Filter:** This is a 10-micron, 1-1/2"-diameter (38-mm), 4"-long polypropylene reusable filter cartridge that is inserted directly into the Lab Series pump (Filter Adapter not required). It features a cleanable blanket-like material that reduces filter purchase costs and disposal problems. It is also used in small tanks where there is simply not enough space for a wider or longer filter. *Flo King Reorder #MMCA (10 micron); MMCB (5 micron); MMCC (1 micron).* **Purity Information:** Filter blanket may contain a surfactant or mineral oil at less than 1 percent. Immersion in boiling deionized water may be desirable for sensitive applications.

**3. Magnum Reusable Filter:** This is a 10-micron, 2-1/2"-diameter (64-mm), 4"-long (102-mm) polypropylene reusable cartridge that attaches to the Filter Adapter and then to the Lab Series pump. It is made of the same filter material as the Mini Mag but offers greater surface area for higher solids-holding capacity and therefore reduced frequency of filter changes. *Flo King Reorder #MCA4 (10 micron); MCB4 (5 micron); MCC4 (1 micron).*

**Possible Option—String-Wound Filter (formerly included with Lab Series but now replaced by Poly-Wrap):** This is a 5-micron, 1-1/2"-diameter (38-mm), 3"-long (76-mm) disposable cartridge that is inserted directly into the Lab Series pump (Filter Adapter not required). *Flo King Reorder #FKL5-3.* **Purity Information:** May contain a small amount of sizing or other impurities. Immersion in boiling deionized water may be desirable for sensitive applications.

### About Mini Mag and Magnum Reusable Filter Cartridges

The blanket-like Mini Mag and Magnum reusable filters (discussed above) minimize the costs and problems associated with filter cartridge consumption and disposal. These cartridges are available in three micron ratings. The 10-micron "A" blanket is for general-purpose filtration; the 5-micron "B" blanket for finer filtration; and the 1-micron "C" blanket for extra-fine filtration. The reusable material is made entirely of thermally bonded polypropylene fibers. Depending on the type of solution, the method of cleaning the filters, and other factors, it may be possible to reuse the filters up to 100 times or more. The reusable filters are available in lengths to 20". **Purity Information:** Filter blanket may contain a surfactant or mineral oil at less than 1 percent. Immersion in boiling deionized water may be desirable for sensitive applications.

### Popular Option: High-Purity Poly-Spun Disposable Filter Cartridges, 2-1/2" Diameter

Another popular filter you may wish to consider (although not included with your Lab Series system) is the polypropylene-spun ("Poly-Spun") disposable cartridge. Available in numerous micron ratings, Poly-Spun cartridges have a coreless, self-supporting structure made entirely of thermally bonded polypropylene fibers. **Purity Information:** Because no resins, binders, lubricants or anti-static agents are used in manufacturing, no pre-wash is required. The service temperature is up to 200° F for most applications. *Specify length and micron rating when ordering. Note: Poly-Spuns are available in lengths from 4" to 50" (10 to 127 cm).*



## MAGNUM REUSABLE FILTER CLEANING & ASSEMBLY INSTRUCTIONS

Refer to Safety Precautions on Page 2. Solution Safety Procedures Must Be Followed To Prevent Injury or Damage to Personnel and Environment.

1. Remove Magnum filter cartridge from Impeller Housing. Let drain and/or place in container.

2. Remove outside plastic web. Stand cartridge assembly on flat surface in upright position. Grasp with both hands and slide web down about 2 or 3 inches (5 or 10 cm). Hold on to exposed filter blanket with one hand and pull web off Magnum assembly with twisting motion. (NOTE: If web is "locked on" with sludge, it may be necessary to spray outside of Magnum with water to "unlock" web.)

3. Unroll filter blanket from filter core. Most users then lay blanket on piece of grating over suitable tank, drum, reservoir or wastewater treatment pit and spray each side using an ordinary hose and spray nozzle (or, if available, pressure spray washer). Normally, this is sufficient for cleaning; however, some contaminants may build up and not flush out completely. In many applications, these contaminants can be removed easily by placing Magnum blanket in an appropriate chemical solution.

**CAUTION: Never mix cyanide-laden materials with acids; this combination produces hydrogen cyanide gas, which is lethal if inhaled! The process solution to which the Magnum has been exposed must be compatible with the acid from a SAFETY and USE standpoint.**

4. To wrap Magnum blanket around filter core, lay blanket on flat surface. Blanket can be rolled while wet. Place core on blanket, making sure that top of blanket is even with core, and roll as tight as possible. (Note: If using PERMACORE filter element, allow PERMACORE head to lay off edge of flat surface while rolling blanket.)

5. Rest Magnum assembly in one plastic loading slat and place other loading slat on opposite side of Magnum filter to form a tube. Make sure plastic loading slats extend 2 inches (5 cm) beyond one end of Magnum.

6. Grasp Magnum about 4 inches (10 cm) from extended end. Slip plastic web over loading slats and pull down to end of assembly. Remove loading slats. Magnum is now ready to be used again.

*Special Notes for Lab Series Users: If you are using 4"-long Mini Mag and Magnum reusable filters, extend loading slats just 1" beyond one end of filter blanket. Then, with one hand, grab opposite end of assembly. With other hand, slip plastic webbing over loading slats and pull webbing down to end of assembly. Finally, remove loading slats.*



Clean blanket.



Re-roll blanket around core.



(L-r) Place plastic loading slats over filter. Then slide web over slats and pull down. Remove slats and cartridge is ready to reuse.



## **PREMATURE FILTER CLOGGING**

### **Filter Changes When Starting Up Your Flo King System**

When you install your Flo King in a previously unfiltered or poorly filtered bath, you may find that dirt, sludge, and other solids emerge from the bottom of the tank.

Consequently, until removed, these built-up solids may cause your Flo King filters to clog up quickly.

Do not be alarmed!

This is exactly what your Flo King system was designed to do. The counterflow action and quick-capture features of the Flo King system result in efficient filtration by suspending and then capturing the solids.

A few simple changes of the reusable Magnum filter will normally put your bath in good condition. (See “Cleaning & Assembly Instructions for Flo King Magnum Filter Cartridges” on Page 9.)

However, if your bath has a considerable solids build-up and you wish to avoid filter clogging and get a fresh start on your filtration program, we suggest you follow the “DE-SLUDGE Procedure” outlined on Page 11.



## **DE-SLUDGE PROCEDURE**

### **For Cleaning & Purifying Dirty, Contaminated Solutions**

Refer to Safety Precautions on Page 2.

Solution Safety Procedures Must Be Followed

To Prevent Injury or Damage to Personnel and Environment.

These instructions for cleaning and purifying dirty and contaminated solutions are recommended for most plating and associated process solutions in the finishing industry. These instructions are a guide, however, and depend on qualified personnel for proper cleaning and operation of filter media and carbon purification methods.

#### **Solids Removal**

1. De-Sludge: Let solution settle for 24 hours or until sediment has dropped to bottom of tank.
2. De-Cant: Remove solution from tank very carefully, without disturbing sediment on bottom of tank. Remove sludge, clean tank, and pump solution back into tank. (See Flo King Catalog Bulletin 32, "Special Applications")
3. Filter: Place one or two Flo King filter systems on side of tank with directable outlet extension slanted slightly toward tank wall. This will start a counterflow agitation motion, which directs dirt and particles into filter media for solids removal.

Using Flo King Magnum or Super Magnum reusable filter cartridges or FK50 Poly-Spun disposable cartridges (see Catalog Bulletins 24 and 26), continue filtering until filter cartridges clog. This is determined visually by observing the solution; when there is little or no solution movement, the filter cartridges have clogged. Change or clean filter cartridges and continue filtering until filters are able to run several hours without plugging up. Ten turnovers generally produces a bath that filters particles in the range of 10 to 15 microns; 20 turnovers typically results in a 1- to 5-micron bath.

#### **Carbon Purification**

If solution is still cloudy after following the above procedure or if tests show the presence of organic contamination, carbon purification may be necessary. (Refer to Flo King Catalog Bulletin 28 for system size and method of carbon purification needed.)

1. Place carbon system in tank and run for several hours or overnight.
2. Test solution for organic contamination and continue until results are satisfactory.



## FLO KING LAB SERIES TROUBLESHOOTING

### 1. Symptom: Little or No Agitation or Solution Circulation.

**Possible Problems:** (a) Solution level is not above “Weep Hole” immediately above Discharge Port on pump Body. In general, solution should be at least 1" above Weep Hole (refer to illustrations on Pages 3 and 16). This will ensure that Impeller is submerged and spinning in solution. (b) Filter is clogged. Refer to “Premature Filter Clogging” and “De-Sludge” sections on Pages 10 and 11, respectively. (c) If problem persists, wrong filter media may be in use. Refer to Page 8, “Lab Series Filter Cartridges” (also see Flo King Bulletins 24 and 26 in catalog). Note: Filter cartridges that are too fine for the application can “choke” intake of pump, thus substantially reducing flow rate and agitation. Try a coarser cartridge (higher micron rating). (d) A foreign object has lodged inside Impeller Housing (also look for buildup of chemical residues). Turn pump off and remove from solution as outlined in instructions, “Removing Lab Series from Tank...”. Remove foreign object or residue from Impeller area, then re-install pump according to “Lab Series Installation” instructions on Page 5.

**Important: To prevent foreign objects from getting trapped inside Impeller Housing, never run pump without either a filter cartridge or a strainer accessory.** When using a filter cartridge, *always* remember to install Filter Plugs at bottom of filter cartridges. When using pump without filter cartridge, *always* attach Lab Series strainer accessory (*Pump Strainer Adapter, Order# PSAL*) to prevent damage to Impeller from any foreign objects that might be in solution.

### 2. Symptom: Excessive Pump Vibration.

**Possible Problem:** Pump Shaft is out of alignment—normally due to excessively rough handling during shipping or use. If this occurs when unit is just received, immediately call the shipper and Flo King factory (or your area Flo King distributor) to report damage (see “Before Unpacking Your Unit,” Page 1.) In any case, it is recommended that Shaft realignment be done at Flo King factory.

### 3. Symptom: High-Pitched Noise and Rattle.

**Possible Problem:** Bearings may need replacement, a service offered by Flo King factory. **Comment:** A drop of oil on noisy bearings may reduce noise temporarily.

### 4. Symptom: Loud, Screaming Noise.

**Possible Problem:** (a) Motor Fan Blade is too high and rubbing against Motor Cover. This may occur if Fan Blades are inadvertently bent after removal of Motor Cover for maintenance, etc. Referring to Page 7, “Periodic Maintenance Procedure,” remove Motor Cover and gently adjust Fan Blades to approximately 1/16" inch (1.6 mm) above highest point on Motor. Do not adjust Fan Blades too low. Fan Blades should not be permitted to contact Motor.

### 5. Symptom: Loud, Clicking Noise.

**Possible Problem:** Motor Fan Blade is too low and rubbing against top of Motor. This may occur if Fan Blades are inadvertently bent after removal of Motor Cover for maintenance, etc. Referring to Page 7, “Periodic Maintenance Procedure,” remove Motor Cover and gently adjust Fan Blades to approximately 1/16" inch (1.6 mm) above highest point on Motor. Do not adjust Fan Blades too high. Fan Blades should not be permitted to contact Motor Cover.



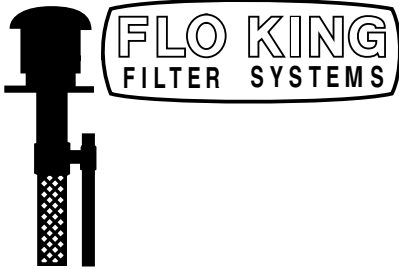

## LAB SERIES REPAIR INFORMATION

**PUMP MODEL IDENTIFICATION:** Before ordering parts, you must determine the pump model and, for many order items, the pump body length (see “Determining Pump Body Length” below). The model and body length do not appear on the pump body or motor. To identify the pump model, either: (1) check your original Flo King invoice; (2) write down the serial number, which appears on a silver sticker on the motor, then contact the Flo King factory for identification; (3) look for the horsepower rating on the motor: Unless the unit has been made for a special application, a 1/70th-hp motor is used on the Lab Series model; 1/15th hp on the BX650; 1/12th hp on the BX1200; 1/3 hp on the BX3000 and BXL2500; and 3/4 hp on the BX5000 and BXL5000; (4) compare your pump appearance and specifications with the photographs and specifications shown for each model in our catalog bulletins; or (5) contact the Flo King factory for further assistance.

**DETERMINING PUMP BODY LENGTH:** Flo King pumps are manufactured with different body lengths to satisfy the solution level from the top of the tank (freeboard) and, in many cases, the depth of the tank. You must therefore determine the length of your pump body and shaft before ordering certain parts. To determine the pump body length of the Lab Series, measure the “A” Dimension shown in the illustration at right. Then refer to the table to find the corresponding pump model, such as LBS4 (PP-LBS4 for standard polypropylene model).

**PUMP MATERIAL OF CONSTRUCTION:** It is essential that you identify the pump material of construction before ordering parts. If the pump body is white in color, the unit is made from polypropylene; if gray, CPVC. In recent years, all standard Lab Series units have been constructed of polypropylene. CPVC, Kynar (PVDF) plastic, and stainless steel are also sometimes specified on a special-order basis. If you are uncertain, check your original invoice or contact the Flo King factory for further assistance.

**PARTS AND SERVICE PRICES:** The prices shown in our catalog under “Factory Service & Parts” include both parts and installation by our factory. In most cases, prices are the same for parts alone.

**SERVICE:** Our Repair Department is staffed by trained technicians and provided strictly as a service to Flo King users. We encourage you to take advantage of this service program. You will receive warranty coverage on all repairs we make. Use of independent motor repair shops is strongly discouraged! In our experience, they will always be more expensive because (1) Flo King factory repair prices already include labor and (2) their unfamiliarity with the design of our products can cause more damage and repair costs. For these reasons, we do not give technical assistance, drawings or parts information to independent motor repair shops.

**RETURN PROCEDURE:** Clean equipment in accordance with shipping regulations and send to **REPAIR DEPARTMENT, FLO KING/CUSTOM MASTERS, 401 LAKE BENNETT CT., LONGWOOD, FL 32750-6341** USA. Make sure to include your name, address, and phone number so that the repair technician can contact you with an evaluation and estimate. A Return Authorization Number is not required. Use of the original Flo King box and packing will result in secure transport of your equipment and avoidance of factory charges for a new container.

**ADDITIONAL REPAIR INFORMATION:** Visit our website at [www.floking.com](http://www.floking.com)

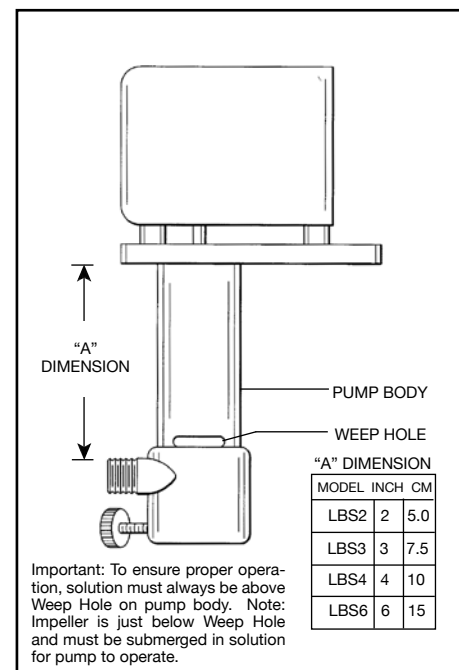



## **FLO KING LAB SERIES REPAIRS: DISASSEMBLY**

**FOR PARTS IDENTIFICATION, PLEASE REFER TO EXPLODED VIEW OF LAB SERIES ON PAGE 13.**

**Note:** Impeller removal is the first step toward disassembling the Lab Series. To replace a damaged Motor, most customers order a Motor with Balanced Teflon-Coated Shaft Attached. This is much easier to install than just replacing the Motor and is more dependable because the Shaft is already balanced on the new Motor.

**1. Remove Flow Plate.** Gently strike one edge of Flow Plate with a small hammer and blunt object (like a Phillips-head screwdriver). Flow Plate should pop out easily.

**2. Remove Blue Motor Cover.** Remove Motor Cover Hardware (three screws), then slide off Motor Cover to expose Fan Blade.

**3. Remove Impeller.** Gently hold Fan Blade with one hand. Be careful not to break Fan Blade! With other hand, use needlenose pliers to turn impeller COUNTERCLOCKWISE.

**4. Install New Impeller.** Hold Fan Blade firmly while threading new Impeller CLOCKWISE onto Shaft. Caution: Do not spin Fan Blade to tighten Impeller! This can result in cross-threading.

### **FURTHER REPAIR INFORMATION**

Visit our website at [www.floking.com](http://www.floking.com)